

Except for the assumption of a definite form of function, the Storch equation, the method of Bates rests upon substantially the same character of a foundation as the one proposed by the writer, being in fact an analytical method for attaining the end which the writer secures by a graphical process. As a matter of fact when both methods are applied to the data for potassium chloride they give very nearly the same result for Λ_0 . The Λ_0 values given by Bates' method are on the average only about 0.05 unit lower than those obtained by the writer's method, as shown in Table VI.

[CONTRIBUTION FROM THE LABORATORY OF PHYSICAL CHEMISTRY OF THE UNIVERSITY OF ILLINOIS. PUBLICATION No. 31.]

THE EQUIVALENT CONDUCTANCE OF ELECTROLYTES IN DILUTE AQUEOUS SOLUTION.

III. A STUDY OF DILUTE SOLUTIONS OF POTASSIUM CHLORIDE.¹

BY HENRY J. WEILAND.¹

Received September 25, 1917.

CONTENTS.—1. The Preparation of Ultra-Pure Conductivity Water. (a) The Work of Previous Investigators. (b) Outline of the Distillation Process Employed in This Investigation. 2. Description of Apparatus and Experimental Procedure. (a) Description of Apparatus. (b) Collecting the Ultra-Pure Conductivity Water. 3. The Conductivity of Dilute Solutions of Potassium Chloride. (a) Preparation of the Solutions. (b) Densities of the Solutions. (c) Determination of the Cell Constant. (d) The Conductivity Data. 4. The Adsorption of Potassium Chloride by Quartz. (a) The Adsorption Correction and Method of Determining It. (b) Preparation of the Quartz Fragments. (c) Determination of the Surface of the Quartz. (d) Experimental Procedure and Results. (e) Calculation of the Adsorption Correction. 5. Discussion of the Results of the Investigation. (a) The Experimental Error. (b) Consistency of the Data. (c) Calculation of Λ_0 and of K_0 . (d) Conductance Values at Round Concentrations. (e) Potassium Chloride and the Law of Mass Action. (f) The Interpolation Equations of Kraus and of Bates. 6. Summary.

1. The Preparation of Ultra-Pure Conductivity Water.

(a) **The Work of Previous Investigators.**—The purest water ever obtained was that prepared by Kohlrausch and Heydweiller in 1894. Their process consisted in the repeated back-and-forth distillation of water between two evacuated glass vessels, one of which was provided with electrodes. After 42 distillations of this kind Kohlrausch and Heydweiller obtained water with a minimum conductance of 0.043×10^{-6} reciprocal ohms at 18°. The quantity of water prepared in this way was but a few cubic centimeters, not a sufficient quantity to be used in measuring the conductivity of solutions of electrolytes.

The attempts of later investigators in this field have been directed toward the problem of preparing conductivity water for use in making up

¹ Based upon a thesis submitted to the Graduate School of the University of Illinois, by the author, in partial fulfillment of the requirements for the degree of Doctor of Philosophy in Chemistry, June, 1917.

and measuring the conductivity of solutions, and since a review of the investigations upon this subject has recently been published by Kendall¹ further discussion of the subject will be omitted here. For the sake of completeness, however, mention may be made of the fact that in addition to the examples, cited by Kendall, of very pure conductivity water obtainable by distillation in contact with the atmosphere, investigators in this laboratory² have at times obtained water, by a single distillation of ordinary laboratory "distilled water," which had an initial and transitory specific conductance as low as 0.15×10^{-6} at 25° .

(b) **Outline of the Distillation Process Employed in This Investigation.**

—The process employed for obtaining the ultra-pure conductivity water required for this investigation consisted in heating about 13 liters of good conductivity water (0.6 to 0.8 water) in a quartz still (Fig. 6) and at the

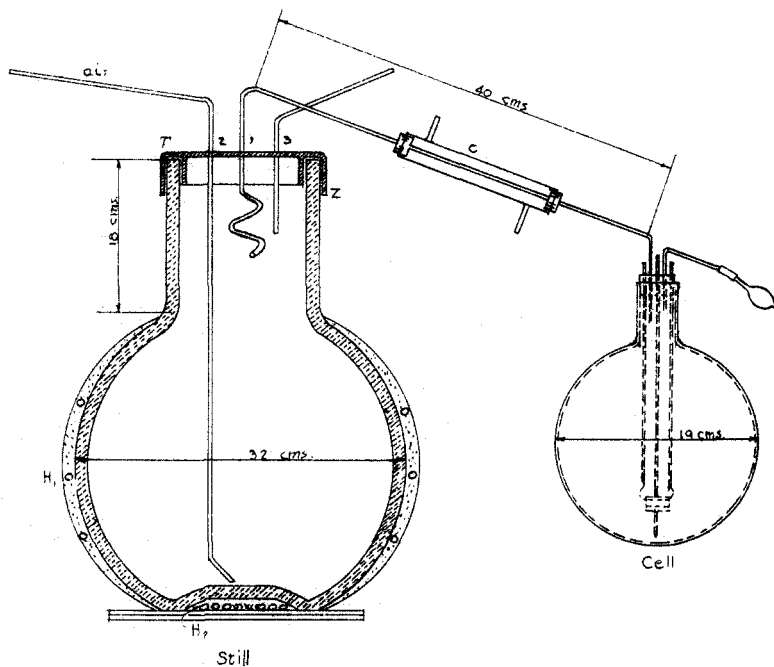

Fig. 6.—The distillation apparatus and conductivity cell.

same time passing a stream of carefully purified air through the water, which was maintained at a temperature a few degrees below its boiling point. This process³ sweeps out of the water practically all of the dissolved gases which it contains without carrying over by entrainment any

¹ THIS JOURNAL, 38, 2460 (1916).

² See Bell, Univ. of Ill., Thesis, 1913, p. 15.

³ The same principle is applied in a different way in the apparatus of Bourdillon, *J. Chem. Soc.*, 103, 791 (1913).

particles of the liquid itself. This sweeping out process was continued for about 20 hours, after which a conductivity cell (Fig. 7), consisting of a three-liter quartz flask fitted with sealed-in platinum electrodes,¹ was

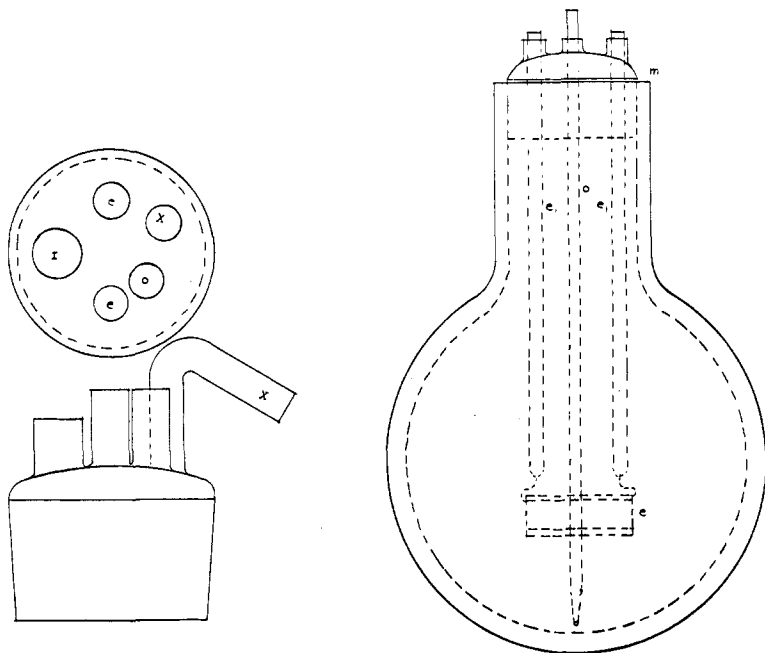

Fig. 7.—The conductivity cell.

attached to the block tin condenser of the above still and a distillate of about two liters was collected. If this distillate was found to be not sufficiently pure, it was drawn out of the cell by means of a quartz tube provided for that purpose and a second distillate was collected in the same way. This process of collection and rejection was then continued until finally about three liters of water having a specific conductance between 0.05 and 0.07×10^{-6} reciprocal ohms was obtained.

Since as explained in Sec. 2 of the first paper of this series nothing would be gained by employing water of a higher degree of purity than this, no attempt was made to prepare such water in connection with this investigation. The apparatus devised for this investigation could, however, readily be adapted to a repetition of the work of Kohlrausch and Heydweiller for the purpose of ascertaining what the conductivity of the purest water is.

¹ Thanks are due to Drs. R. D. Mailey and F. G. Keyes of the Cooper Hewitt Company for their valued assistance in making this difficult and important seal for us and thus placing at our disposal a pair of electrodes which have proved entirely satisfactory in every respect.

2. Description of Apparatus and Experimental Procedure.

(a) **Description of Apparatus.**—In order to save space a detailed description of the apparatus and experimental methods will be omitted here, since this description is given in the author's thesis.¹ It will suffice to say that all necessary precautions were taken to insure the highest attainable degree of accuracy in the measurements. The conductivity water and the solutions were kept under pure air purified by means of the apparatus shown in Fig. 8. The measurements were carried out in an

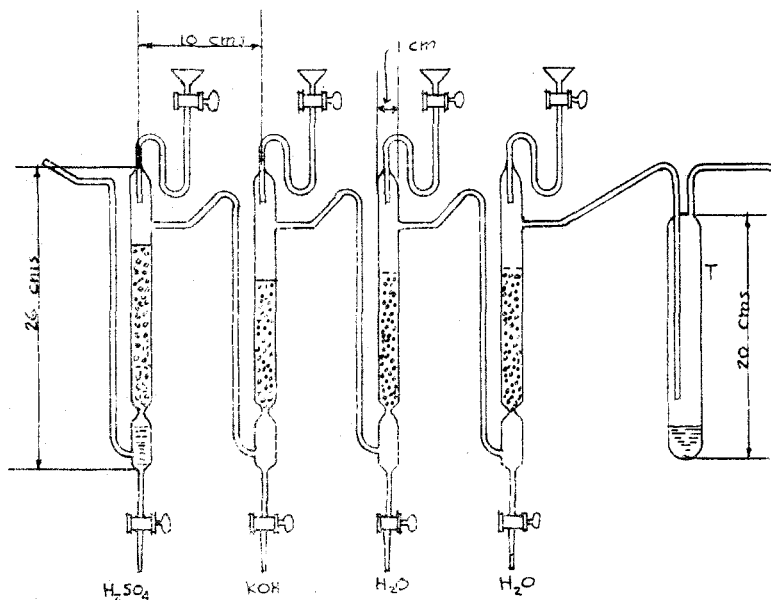

Fig. 8.—The air purification apparatus.

oil thermostat maintained constant to 0.01° and the electrical measurements were made with the apparatus described by Washburn and Parker¹ and are referred to resistance standards certified by the National Bureau of Standards. Previous to each set of measurements the electrodes were thoroughly cleaned by steaming them in the apparatus shown in Fig. 9. The solutions were made up in the conductivity cell by adding small individual crystals of the salt weighed on an assay balance and the solution was stirred constantly by a stream of purified air previously saturated and brought to the temperature of the bath.

(b) **Collecting the Ultra-Pure Conductivity Water.**—By the procedure described in Sec. 1, it was always possible with one filling of the large quartz still to obtain at least three liters of ultra-pure conductivity

¹ For copies of this thesis application should be made to the Librarian of the University of Illinois, Urbana, Ill.

¹ THIS JOURNAL, 38, 2431 (1916); 39, 235 (1917) and a paper not yet published.

water. The quality of the water obtained in seven distillations is shown in Table II.

TABLE II.
Specific Conductance of Ultra-pure Conductivity Water Prepared on Different Dates.
Temp. 18°.

Date.	12/28/'15.	1/15/'16.	3/18/'16.	2/2/'17.	2/19/'17.	2/24/'17.	3/6/'17.
$L_w \times 10^6$.	0.057	0.059	0.062	0.066	0.061	0.063	0.053

Water of this degree of purity can be kept in the quartz cell practically unchanged for periods as long as 12 hours, provided the stream of purified air is kept slowly bubbling through it. Some experiments were made to determine whether any pollution of the water was caused by withdrawing the stopper from opening 1 (Fig. 7) for 30 seconds and then replacing it. No change in the conductivity of the water could be detected under these circumstances. In making a series of conductance measurements of dilute solutions the length of time required is from two to three hours. The above experiments show that there is no danger of the water becoming appreciably contaminated during the time required for such a series of measurements.

3. The Conductivity of Dilute Solutions of Potassium Chloride.

(a) **Preparation of the Solutions.**—The potassium chloride employed in this investigation was Kahlbaum's special "K" product which was recrystallized three times from conductivity water, dried with the aid of a centrifuge and finally fused in platinum. It was kept for use in small weighing bottles over calcium chloride in a desiccator.

The solutions were made up by dropping successive small crystals into the cell. The crystals were weighed out on the small platinum balance pan and then transferred carefully to a shallow platinum bucket made from platinum foil. The salt crystals and the bucket were then dropped together into the conductivity cell. Blank experiments using the platinum alone demonstrated that no contamination of the water occurred during this operation.

It had been the original intention to use a microbalance for weighing the salt crystals but the balance provided for this purpose was not in shape for use at the time the final experiments were started and since there was not sufficient time to have it repaired recourse was had to a good assay

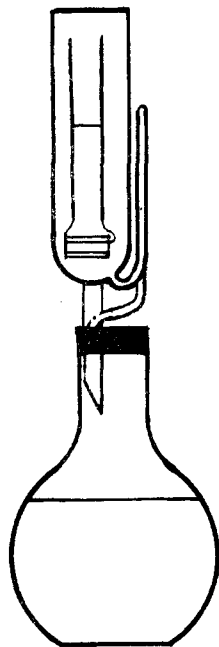

Fig. 9.—Apparatus for cleaning the electrodes.

balance which had a sensitivity of 0.001 mg. with a load of 20 mg. The weights employed had been calibrated at the U. S. Bureau of Standards. At the end of a series of measurements the conductivity cell and its contents were removed from the bath and weighed. The contents of the cell were then poured out and, after cleaning and drying, the cell and electrodes were again weighed thus giving the total weight of the final solution measured, which together with the weights of the different portions of salt added gave the necessary data for calculating the concentrations of the series of solutions. All the weighings were reduced to *vacuo*.

(b) **Densities of the Solutions.**—The densities employed in computing the concentrations of the solutions were calculated from the data of Lamb and Lee¹ by means of the following equation which is based upon their data:

$$D_{18^{\circ}/4^{\circ}} = 0.998622 + 485 \times 10^{-4} C \quad (52)$$

(c) **Determination of the Cell Constant.**—The conductance values given in this paper are based upon the assumption that a solution of potassium chloride containing 7.43000 g. of salt in 1000 g. of solution (weights in air) has a specific conductance of 0.01288 reciprocal ohm at 25° and a specific conductance of 0.00715 reciprocal ohm at 0°. The cell constant was determined as follows:

The constant of a conductivity cell of type B² was first determined by measuring its resistance when filled with the above 0.1 *N* solution of potassium chloride at 25°. The value of its constant was found to be 0.6043 which checked to 0.02% a determination previously made by Clark who employed this same cell in 1915. Clark found the value 0.6044 at 25° and 0.6030 at 0°, giving for 18° the value 0.6040. After having determined the cell constant of this auxiliary cell in this manner, a comparison solution, approximately 0.001 *N* with respect to potassium chloride, was made up using conductivity water with a specific conductance of about 0.8×10^{-6} reciprocal ohms. The resistance of this comparison solutions was then measured in the auxiliary cell and also in the quartz cell employed in this investigation, and in this way the cell constant of the latter cell could be calculated. The results are shown in the following table:

Date.	Resistance in quartz cell.	Resistance in comparison cell.	Cell constant of quartz cell.
Feb. 26.	146.443	3631.62	0.024356
March 6.	134.366	3333.23	0.024348
March 16.	118.222	2932.22	0.024352
			Value adopted, 0.024354

In addition to the above determination of the cell constant, an additional check was obtained in three of the runs by adding sufficient salt to bring

¹ Lamb and Lee, *THIS JOURNAL*, 35, 1687 (1913).

² Washburn, *Ibid.*, 38, 2449 (1916).

the final concentration of the solution up to about 0.001 *N*, at which concentration a comparison with the conductance data of Kohlrausch and Maltby could be directly made. This comparison is shown in Curve A of Fig. 10, the concentrations being indicated at the top of this diagram

TABLE III.

Values of the Specific Conductance and Equivalent Conductance of Potassium Chloride Obtained in the Different Series of Experiments. Temperature, 18 ± 0.01°.

Equivalent Weight of Potassium Chloride = 74.560. All Weights

Reduced to *vacuo*.

$C \times 10^6$. (Micromols per liter.)	$L \times 10^8 = (L_s - L_w) \times 10^6$. ("Water corrected.")	Δ_c . Equivalent conductance.
Jan. 24, 1917. $L_w = 0.07404 \times 10^{-6}$.		
23.958	3.10226	129.490
46.129	5.96758	129.368
81.343	10.5047	129.141
119.574	15.4176	128.938
183.019	23.5580	128.720
Feb. 2, 1917. $L_w = 0.06645 \times 10^{-6}$.		
7.4945	0.96881	129.268
26.467	3.42878	129.547
42.251	5.46522	129.351
74.563	9.62983	129.149
102.58	13.2337	129.005
Feb. 10, 1917. $L_w = 0.06998 \times 10^{-6}$.		
23.821	3.08509	129.518
58.647	7.58402	129.315
103.837	13.4033	129.080
1021.87	130.007	127.224
Feb. 24, 1917. $L_w = 0.06330 \times 10^{-6}$.		
31.951	4.13537	129.430
61.994	8.00763	129.166
123.36	15.9024	128.911
958.22	121.993	127.312
Mar. 6, 1917. $L_w = 0.05335 \times 10^{-6}$.		
26.960	3.48776	129.369
60.878	7.86092	129.125
104.17	13.4308	128.926
154.14	19.8425	128.738
236.09	30.3397	128.510
1299.02	1648.06	126.869

and the values of Λ_c at the right. From the above data it is evident that the cell constant is known with a precision of about 0.02 per cent.

(d) **The Conductivity Data.**—Five separate series of experiments were made with potassium chloride, the results obtained being shown in Table III. The specific conductance values shown are the ordinary "water corrected" values; that is, they are the measured specific conductances diminished by the conductance of the water in each case. A calculation of the metathesis correction on the assumption that the only impurity present in the water was carbon dioxide was made with the aid of Equations 8 and 30 to 34 inclusive, as described in the first paper of this series. The results showed that for the most dilute solution measured this metathesis correction amounted to only 0.0018% and was accordingly negligible. It would also be negligible even if a substantial amount of the residual impurity were a neutral salt.

4. The Adsorption of Potassium Chloride by Quartz.

(a) The Adsorption Correction and Method of Determining It.—

In calculating the concentrations of these very dilute solutions of potassium chloride it is necessary to know whether or not an appreciable adsorption of the salt takes place on the quartz walls of the conductivity cell. Briggs¹ who studied the adsorption of hydroxides and carbonates of several metals by quartz found an appreciable adsorption. In the case of the chlorides of potassium, sodium and ammonium, however, he did not succeed in detecting any appreciable adsorption. Kohlrausch² also studied the possibility of an adsorption of neutral salts by the electrodes and concluded that no appreciable error from this source was to be feared.

In order to determine the magnitude of the adsorption coefficient of potassium chloride by quartz, the following method was employed: The specific conductance of a dilute solution of potassium chloride was first measured in a special cell arranged for the purpose and then a definite quantity of well cleaned quartz fragments were dropped into the solution and the specific conductance again determined. Knowing the change in conductance and the total quartz surface involved, the adsorption coefficient could be calculated.

(b) **Preparation of the Quartz Fragments.**—The quartz fragments employed in this study were prepared from pieces of broken quartz apparatus. The fragments were first broken up into small pieces and then ground in a ball mill. The resulting quartz powder was then washed thoroughly until a good grade of conductivity water showed no increase in conductivity after being stirred with the quartz fragments. The quartz fragments were then dried in a quartz flask, being heated to 300° C. to drive out the last traces of water.

¹ Briggs, *J. Phys. Chem.*, 9, 624.

² Kohlrausch, *Ges. Abhandl.*, 2, 381.

(c) **Determination of the Surface of the Quartz.**—The surface of one gram of the quartz fragments was determined as follows: The entire amount of quartz was first separated into fractions by means of a set of standard sieves. The weight of each fraction was determined and the average diameter of the particles of each fraction was measured by means of a micrometer microscope. In calculating the surface of the particles they were assumed to be perfect spheres. The calculated surface was therefore much less than the true surface because the particles of quartz were of very irregular shapes. The surface of each fraction was calculated from the average diameter of the particle, the weight of the fraction, and the specific gravity of the quartz. The composition of the quartz thus determined is shown in Table IVa, from which we find that the total surface of the quartz was about 347 sq. cm per g., this value being, for the reasons stated, a lower limit.

TABLE IVa.

Sieve, meshes per inch.	Average diameter in mm.	Total surface of fraction. Sq. cms. 10^{-3} .	Weight of fraction in g.
40	0.282	0.120	1.25
60	0.246	0.678	6.15
80	0.149	2.405	13.20
100	0.0968	2.425	8.65
120	0.0721	1.200	3.19
200	0.0583	3.029	6.51
over 200	0.0320	7.037	8.29
Total,		16.89	47.24

(d) **Experimental Procedure and Results.**—The conductivity cell employed in the adsorption studies consisted of a 250 cc. quartz flask and a pair of plunge electrodes. The cell was first filled with "equilibrium water" and allowed to come to the temperature of the bath. After determining the specific conductance of the water a small weighed crystal of potassium chloride was dropped into the water and the specific conductance of the resulting solution determined. When the conductivity had become constant a weighed amount of clean quartz was then dropped into the solution and after stirring, the conductivity was again measured.

In order to determine the "polluting effect" of the quartz an equal weight of quartz was then added to the conductivity water alone and the increase in conductance of the water noted. This same increase was assumed to take place when the quartz was added to the solution and after making a correction for this "polluting effect" the remainder of the observed change in the conductance of the solution was ascribed to adsorption. The data for two experiments of this character are shown in Table IVb.

TABLE IVb.
Calculation of the Adsorption Coefficient for Potassium Chloride on Quartz.

$$x = \frac{10^3 \Delta L_{Ad}}{129.5 S} \text{ equivalents per liter per sq. cm.}$$

	Specific conductance, $L \times 10^6$.		Specific conductance, $L \times 10^6$.	
	Water.	Solution.	Water.	Solution.
After adding quartz.....	1.05483	105.770	1.0394	144.095
Before adding quartz.....	0.93033	105.748	0.9458	144.066
ΔL	0.124	0.022	0.0936	0.029
ΔL^s	0.022		0.029	
ΔL_{Ad}	0.102		0.065	
Surface of quartz, S	17350 sq. cm.		16650 sq. cm.	
Volume of solution, V	0.217 l.		0.235 l.	
Adsorption coefficient, x	9.9×10^{-12}		7.1×10^{-12}	
Conc. of soln., C	0.00083		0.00112	
Final values.....	$C = 0.00112$ $x = 8.8 \times 10^{-12}$			

(e) **Calculation of the Adsorption Correction.**—The inner surface of the three-liter quartz flask employed as the conductivity cell throughout this investigation was calculated from the diameter of the flask to be 1030 sq. cm. The actual surface was somewhat greater than this, owing to superficial irregularities but any uncertainty from this source would produce a smaller and opposite effect from that produced by the assumption previously made that the small quartz particles employed in the adsorption measurements were perfect spheres. The volume of the solution in the flask was taken as 2.8 liters on the average.

The number of equivalents of potassium chloride adsorbed by the surface of the cell from one liter of a 0.001 *N* KCl solution will therefore be $1030 \times 8.8 \times 10^{-12} / 2.8 = 3.1 \times 10^{-10}$ equivalents and the adsorption correction in per cent. will amount to

$$P_A = \frac{3.1 \times 10^{-8}}{0.001} = 3.1 \times 10^{-6} \quad (53)$$

at this concentration. At lower concentrations the actual amount of potassium chloride adsorbed will be less than that adsorbed from a 0.001 *N* solution so that we may write in general

$$P_A < \frac{3.1 \times 10^{-8}}{C} \quad (54)$$

For the lowest concentration measured in this investigation the above relation gives

$$P_A < \frac{3.1 \times 10^{-8}}{2 \times 10^{-5}} < 0.015\% \quad (55)$$

We may therefore conclude that the adsorption correction for quartz will be negligible for all the solutions employed in this investigation.

5. Discussion of the Results.

(a) **The Experimental Error.**—The accuracy to be expected in the equivalent conductance Λ_c may be estimated from a consideration of the errors in the elementary terms entering into the calculation of this quantity. Resolved into its fundamental terms the expression for Λ_c is as follows:

$$\Lambda_c = \frac{74560 k_c}{D} \left(1 - \frac{R_{Sl} W_{Sl}}{R_W} \right) \quad (56)$$

where D is the density of the solution, W_S is the weight of the salt in grams, W_{Sl} is the weight of the solution in kilograms, R_{Sl} is the resistance of the solution in the cell and R_W is the resistance of the water in the cell, k_c being the cell constant. Now in comparison with the errors in the quantity W_S , the weight of the salt, the errors in all of the other quantities involved are practically negligible. With the balance employed in this investigation, errors in the weight of the salt crystals added to the cell

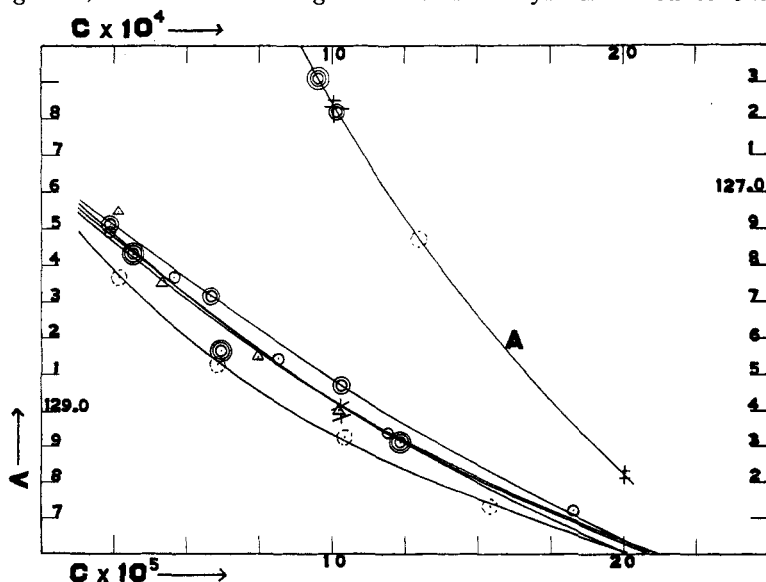

Fig. 10.—For Curve A, the scale of abscissas is indicated at the top of the diagram and the scale of ordinates at the right of the diagram. The small crosses indicate positions of points found by Kohlrausch and Maltby.

might have amounted to as much as 0.05% at the highest dilutions measured and errors in the measured values of Λ_c as large as 0.05% are therefore to be expected.

(b) **Consistency of the Data.**—The data obtained in the five series of experiments are displayed graphically in Fig. 10, values of Λ_c being expressed as ordinates and values of the concentration as abscissas, the scale of abscissas for Curve A being indicated at the top and the scale of ordinates at the right of the diagram. The points for the five different series of experiments are indicated by certain symbols which will be used to distinguish the different series in all of the diagrams employed in the rest of this paper.

Owing to slight changes in the cell constant between two successive series, on account of the washing, handling, etc., of the electrodes, the points obtained in the different series do not lie upon any one smooth curve. Each series was therefore treated separately and a "best" smooth curve was drawn independently through its own points, giving the five curves shown in the figure. Of the five series shown that of March 6th seemed to be inconsistent with the other four and for this reason it will be disregarded in the discussion which follows, and the theoretical considerations will be based upon the values of Λ_c found in the other four series. In Table V are

TABLE V.
Equivalent Conductances at Round Concentrations as Obtained from the Smooth Curve of Each Series of Experiments.

Date.	Concentration $\times 10^4$.			
	0.2.	0.5.	0.75.	1.0.
Jan. 24.	129.515	129.320	129.170	129.030
Feb. 2.	129.510	129.317	129.150	129.015
Feb. 10.	129.537	129.360	129.220	129.080
Feb. 24.	129.500	129.324	129.165	129.020
Mar. 6.	129.427	129.190	129.04	128.93
Average ¹	129.515	129.324	129.176	129.036

shown the values of Λ_c for *round concentrations* as read off from the smooth curve for each of the individual series of experiments, together with the averages calculated from the first four series, the values for the fifth series being excluded as explained above.²

In Fig. 11 the observed values for the first four series are shown, together with the locus of what seemed to be the "best smooth curve" which could be drawn through all of the points. A different and in general a

¹ March 6th data not included in average.

² The inclusion of the values for the series of March 6th would not change the calculated averages by more than 0.02% in any case.

preferable method of locating such a "best curve" was devised later and is discussed below.

(c) Calculation of Λ_0 and of K_0 .—In order to determine the values of these important constants the method devised by Washburn and described in the preceding paper was employed. In this method values of K_E , the Mass-Action expression, were plotted against corresponding

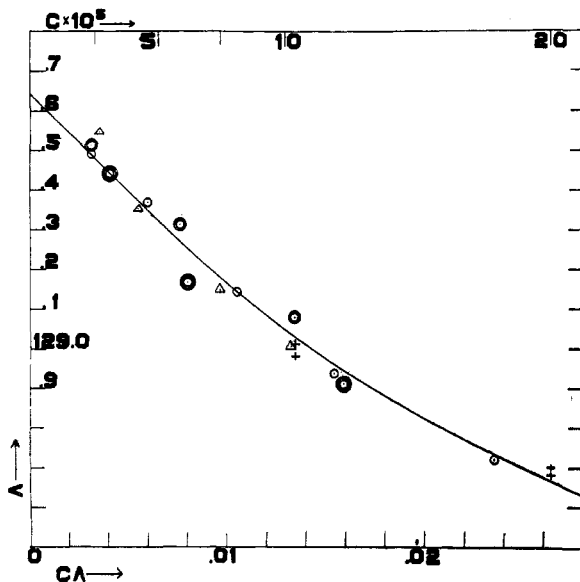

Fig. 11.

values of C , each series of measurements being treated independently. The advantage of treating each series independently instead of employing average values lies in the fact that while the conductivity values them-

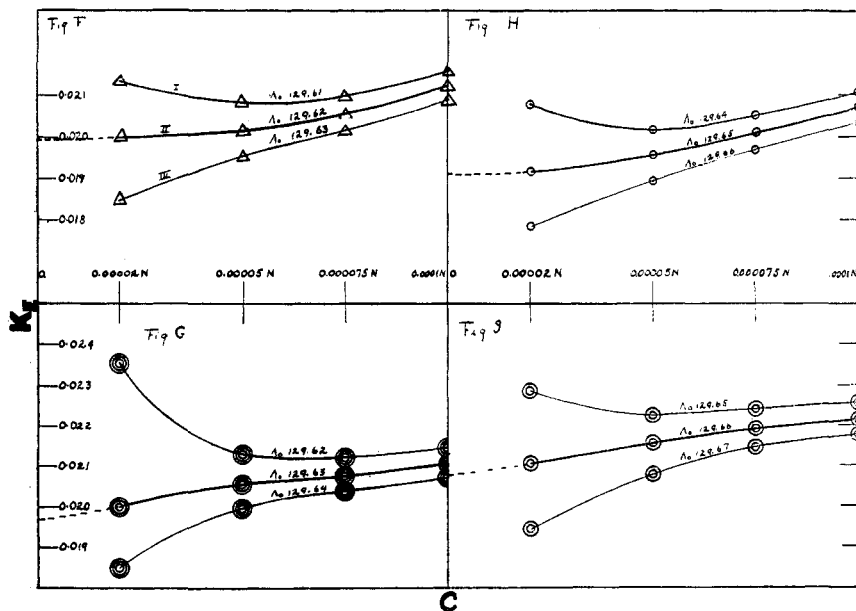

Fig. 12.—The determination of Λ_0 and K_0 values for the individual series of experiments.

selves for the different series may differ slightly, owing to changes in the cell constant, such changes in the cell constant would be without influence upon the values of K_E since the value of the cell constant cancels out of the Mass-Action expression. Values of the Mass-Action expression K_E were computed for each of the first four runs, for the four concentrations shown in Table V, the Λ_c values being taken from that table. Fig. 12 shows the results of this procedure.

From an examination of this figure it is evident that each series of measurements independently fixes a K_o value and a Λ_o value, with a precision of at least 5 per cent. in the case of the former and of at least 0.01 per cent. in the case of the latter. In Table VI are summarized these values of Λ_o and K_o , together with the mean values, the average deviation from this mean and the final values adopted. For comparison, the set of Λ_o values obtained by Bates' method of extrapolation (see the preceding paper, p. 130) when applied to the same data is also included in this table.¹

TABLE VI.
Summary of Λ_o and K_o Values from the Four Series of Measurements.

Date of series.	Λ_o .	d .	K_o .	d .	Λ_o . Bates' method.
Jan. 24.	129.650	0.012	0.0192	0.0011	129.650
Feb. 2.	129.620	0.018	0.0199	0.0004	129.615
Feb. 10.	129.655	0.017	0.0212	0.0009	129.646
Feb. 24.	129.627	0.011	0.0210	0.0007	129.614
Mean.	129.638	0.015	0.0203	0.0008	129.631
Best value.	129.64	± 0.02	0.020	± 0.001	

(d) **Conductance Values at Round Concentrations.**—A set of Λ_c values at round concentrations was obtained by interpolation from a large scale, $C\Lambda_c-\Lambda_c$, curve, the lower part of which is reproduced in Fig. 11. The values thus obtained are recorded in the author's thesis but will not be given here; instead a table of conductance values computed from the corresponding K_E values at round concentrations will be given. The curve from which the K_E values were interpolated was obtained by plotting the K_E values for all the measured points in the five series of experiments, and fitting a "best curve" to these points.² For the higher concentrations

¹ The rejected series (*i. e.*, that of March 6th) if treated in the same way gives for Λ_o the value 129.60 and for K_o the value 0.015. If these values were included in the general average, the averages for the five series would be, for Λ_o , 129.631 instead of 129.638 and for K_o , 0.0192 instead of 0.0203.

² In computing the K_E values for the different series the Λ_o values employed in calculating the difference, $\Lambda_o - \Delta$, were those corresponding to the data for the individual series in each instance rather than the finally adopted average of all the series. This method of calculation is necessary because the accuracy of K_E is determined entirely

the K_E values were computed from the original data of Kohlrausch and Maltby.

The curve thus obtained is shown in Fig. 13. The heavy curve represents what is considered to be the locus of the "best smooth curve" through the points. The two boundary curves above and below this "best curve" represent the shift in the position of this curve which would be produced by a total error of 0.02% that is, by an error of 0.01% in the concentration

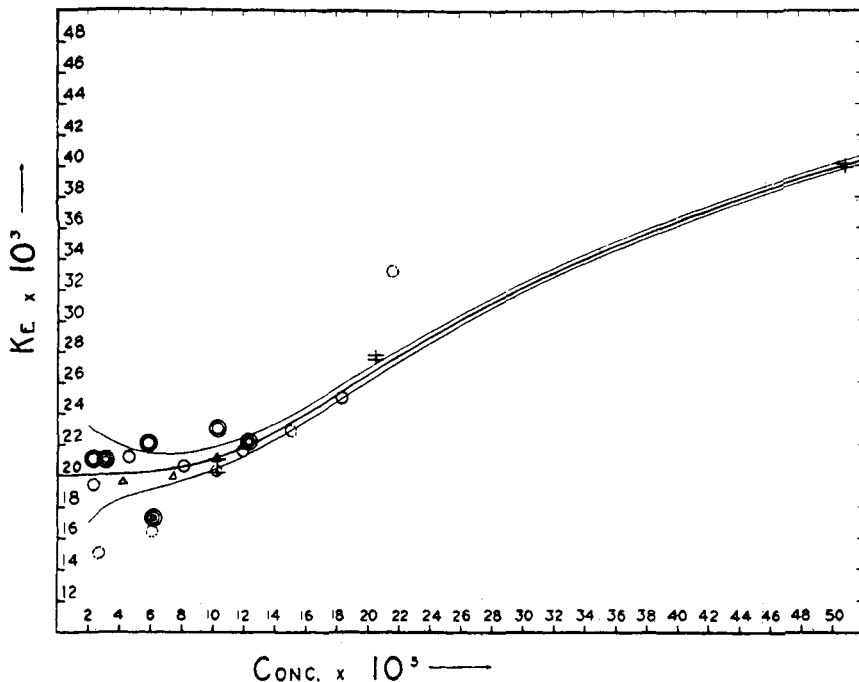

Fig. 13.—The variation of the mass-action expression K_E , with concentration, showing the locations of the observed values for each series of measurements. The crosses represent determinations by Kohlrausch and Maltby.

combined with an error of 0.005° in the temperature of the solution, for example. Since most of the observed points fall within the limits set by these two boundary curves it is evident that the agreement among them is even better than could reasonably have been expected considering all of the difficulties and chances of error involved in the work.

The interpolated K_E values for round concentrations together with the corresponding values of L , Λ_c , and α are given in Table VII. The values of Λ_c obtained in this way do not differ from those directly interpolated by the difference $\Lambda_o - \Delta$, and this difference must, therefore, be chosen for a given series of measurements so as to be consistent with that series, and to be independent of the cell constant.

from the $CA-A$ graph referred to above by more than 0.0046% on the average, the maximum difference being 0.015%. Differences of more than 0.01% occurred only four times. Interpolation from a K_E graph gives a rather more consistent set of data and is therefore to be preferred to any other graphical method of interpolating conductance data.

TABLE VII.

Conductance Data for Potassium Chloride Solutions at Round Concentrations. Temperature, 18.00°. Molecular Weight of Potassium Chloride, 74.560. "Cell Constant" Based upon the Value 0.01288 Reciprocal Ohms for the Specific Conductance at 25° of a Solution Composed of 7.43000 G. of Potassium Chloride in 1000 G. of Solution (Weights in Air).

I.	II.	III.	IV.	V.	VI.
Concentration (Millimol. per liter.) $C \times 10^3$.	True specific conductance $L \times 10^6$ ($\pm 0.02\%$).	Equivalent conductance Λ_c ($\pm 0.02\%$).	$\alpha = \frac{\Lambda_c}{\Lambda_0}$.	$1 - \alpha$.	$K_E = \frac{\alpha^2 C}{1 - \alpha}$.
0.00	0.0	129.64	1.0	0.0	0.020 \pm 0.001
0.01	1.2957 ₃	129.57 ₃	0.9994 ₈	0.0005 ₂	0.020 ₀₀
0.02	2.5902 ₂	129.51 ₁	0.999 ₀₁	0.000 ₉₉	0.020 ₀₂
0.03	3.8833 ₈	129.44 ₆	0.998 ₅₀	0.001 ₅₀	0.020 ₀₃
0.04	5.1753 ₃	129.38 ₄	0.998 ₀₁	0.001 ₉₉	0.020 ₀₆
0.05	6.4660 ₀	129.32 ₀	0.997 ₅₃	0.002 ₄₇	0.020 ₁₄
0.06	7.7554 ₉	129.25 ₈	0.997 ₀₅	0.002 ₉₅	0.020 ₂₂
0.07	9.0437 ₉	129.19 ₇	0.996 ₅₈	0.003 ₄₂	0.020 ₃₅
0.08	10.330 ₉	129.13 ₈	0.996 ₁₃	0.003 ₈₇	0.020 ₅₀
0.09	11.617 ₂	129.08 ₁	0.995 ₆₃	0.004 ₃₂	0.020 ₇₀
0.10	12.902 ₉	129.02 ₉	0.995 ₂₉	0.004 ₇₁	0.021 ₀₂
0.20	25.735 ₆	128.67 ₆	0.992 ₅₇	0.007 ₄₄	0.026 ₅₀
0.30	38.535 ₃	128.45 ₁	0.990 ₈₃	0.009 ₁₇	0.032 ₁₀
0.40	51.297 ₈	128.24 ₄	0.989 ₂₃	0.010 ₇₇	0.036 ₃₃
0.50	64.024 ₀	128.04 ₈	0.987 ₇₂	0.012 ₂₃	0.039 ₇₂
0.60	76.721 ₄	127.86 ₉	0.986 ₃₄	0.013 ₆₈	0.042 ₇₃
0.70	89.397 ₀	127.71 ₀	0.985 ₁₁	0.014 ₈₉	0.045 ₆₃
0.80	102.041	127.55 ₁	0.983 ₈₉	0.016 ₁₁	0.048 ₀₈
0.90	114.66 ₀	127.40 ₀	0.982 ₇₂	0.017 ₂₇	0.050 ₃₄
1.00	127.25 ₈	127.25 ₈	0.981 ₆₃	0.018 ₃₇	0.052 ₄₄

(e) **Potassium Chloride and the Law of Mass Action.**—According to Fig. 13 potassium chloride obeys the law of the Mass Action within the experimental error up to a concentration of about 0.0007 N , in fact the value of K_E increases only about 5 per cent. between 0 and 0.0001 N . This contrasts strongly with the rapid increase of K_E at higher concentrations as illustrated by the data in Table VIII and the curves in Fig. 14. Thus for the first time, direct evidence has been obtained indicating that the ionization of a strong electrolyte in dilute solution takes place in accordance with the requirements of the law of Mass Action and that,

TABLE VIII.

Illustrating the Rate of Increase of the Equilibrium Expression $K_E = \alpha^2 C / (1 - \alpha)$ for a Tenfold Increase in Concentration, over Different Concentration Intervals.

C_1	C_2	K_{E_1}/K_{E_2}
1.0	0.1	4.05
0.1	0.01	3.34
0.01	0.001	2.68
0.001	0.0001	2.49
0.0001	0.00001	1.05

except in degree, there is no difference between the behavior of strong electrolytes and weak electrolytes in this respect. Once having shown that the Mass-Action law is obeyed by strong electrolytes below a given concentration and once having obtained the value of K_0 , it is obvious that the conductance of such electrolytes in the concentration range below the limiting value in question can be accurately and certainly computed.

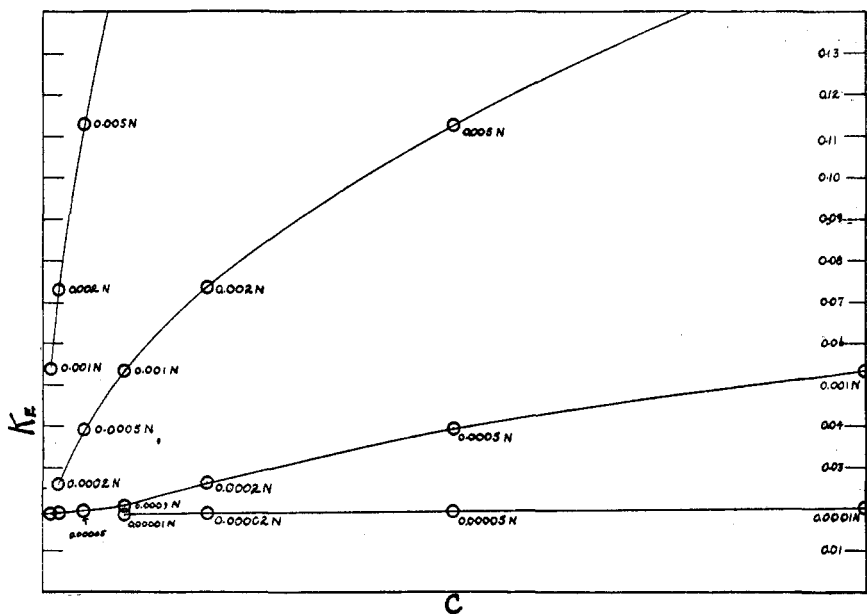

Fig. 14.—Illustrating the behavior of potassium chloride with respect to the mass-action law over different concentration ranges.

(f) **The Interpolation Equations of Kraus and of Bates.**—Kraus and Bray¹ found that the conductance for KCl between 0.001 *N* and 3 *N* could be satisfactorily represented by an equation which may be written in the form

¹ Kraus and Bray, *THIS JOURNAL*, 35, 1315 (1915).

$$\log (K_E - K_o) = \log k + h \log (C\Lambda_c/\Lambda_o) \quad (57)$$

where

$$K_E = \frac{\alpha^2 C}{1 - \alpha} = \frac{\Lambda_c^2 C}{\Lambda_o (\Lambda_o - \Lambda_c)} \quad (58)$$

and K_o , k , h , and Λ_o represent the four parameters to be evaluated from the data.

Similarly, Bates¹ discovered that the same data between the concentrations 0.0001 N and 1 N could be very exactly represented by an equation which may be written in the form

$$\log (\log K_E/K_o) = \log k + h \log (C\Lambda_c/\Lambda_o) \quad (59)$$

where K_o , k , and h , are the three parameters to be evaluated from the data, the value of Λ_o not being determined with reference to this equation but by an entirely different method.

It will be noted that in the form in which they are written above, both of these equations are linear functions and each should therefore give a straight line graph over the range in which it holds. It is interesting to compare these equations in this way with the results obtained in the present investigation which extend to lower concentrations than have ever been attained before. This comparison is made in Fig. 15. Values of $\log \alpha C$

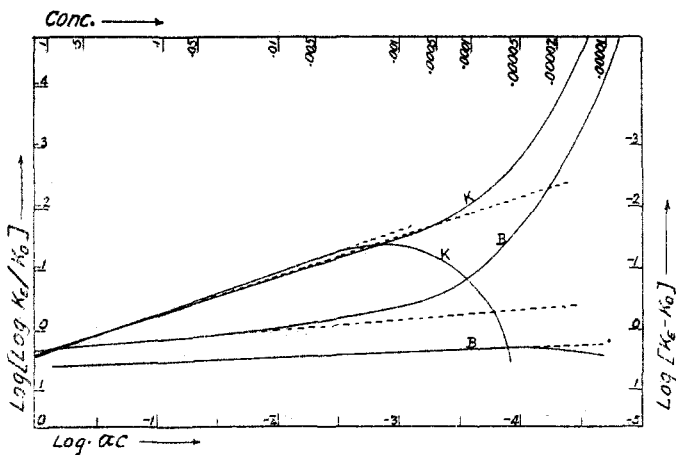

Fig. 15.—Illustrating the applicability of the interpolation equations of Kraus and of Bates, respectively, to the data for $\frac{1}{2}$ potassium chloride.

($= C\Lambda_c/\Lambda_o$ where Λ_c has been corrected for viscosity) are plotted as abscissae. The ordinates for the Kraus equation are shown on the right of the diagram and those for the Bates equation on the left. For convenience a scale of concentration is shown at the top of the diagram. The

¹ Washburn, "Principles of Physical Chemistry," 1915, p. 215, McGraw-Hill Book Co., New York.

straight lines, which are shown dotted in the figure, mark the course which would be followed by the graph if the function were capable of expressing the data. These straight lines have in each instance been located with reference to the data for the higher concentrations.

The lower curve marked K is the curve of the Kraus equation using for Λ_0 and K_0 the values given by Kraus and Bray. It evidently begins to deviate from a straight line at about 0.005 *N*. If the "true values" of Λ_0 and K_0 , as shown in Table VII, be employed in the Kraus equation, the lower curve marked K is obtained.

In the case of the Bates equation the lower curve marked B represents the graph of the equation using for Λ_0 and K_0 the values employed by Bates, and the upper curve marked B represents the graph of the same equation using for Λ_0 and K_0 the "true values" as given in Table VII. With the values employed by Bates, his equation is seen to hold down to about 0.00004 *N* but it fails below that concentration. With the "true values" of these quantities the equation begins to fail at about 0.03 *N*.

Fig. 15 demonstrates clearly that neither of these functions is capable of expressing the data in the lowest portions of the concentration range. Owing to its form the Bates equation is very sensitive to changes in the value of the K_0 parameter and similarly the Kraus equation is sensitive to changes in the constant Λ_0 .

No attempt has been made to fit a single function to the whole K_B curve nor is there any necessity of deriving such a function since the Mass-Action law fits the lower part of the curve accurately and the remainder of the curve up to 1 *N* can be accurately expressed by Bates' interpolation equation, using the parameters employed by him.

6. Summary.

I. Conductivity water with a specific conductance of (0.053–0.070) $\times 10^{-6}$ reciprocal ohms at 18° has been prepared in large quantities by a single distillation of ordinary conductivity water from a quartz still into a quartz cell. This distillation was carried out in air free from carbon dioxide and ammonia.

II. A quartz cell of about three liters' capacity, provided with electrodes in the form of two co-axial platinum cylinders and so constructed that nothing but quartz or platinum comes into contact with the water, has been designed and constructed for measuring the conductivity of the water and of salt solutions prepared in it.

III. Potassium chloride solutions ranging in concentration from 0.00002 *N* to 0.001 *N* have been prepared in this conductivity water out of contact with the atmosphere by the successive introduction into the cell of small crystals of salt weighing about 0.005 g. The electrical conductivities of these solutions have been measured and their equivalent conductances calculated.

IV. In order to ascertain the magnitude of the concentration change due to the adsorption of the salt on the walls of the cell, the specific adsorption of potassium chloride was determined by the use of a large quantity of quartz fragments. This was accomplished by observing the conductivity of 0.001 *N* to 0.0005 *N* solutions of potassium chloride in a special quartz cell before and after the addition of a definite quantity of well cleaned quartz fragments. Knowing the magnitude of the surface of the fragments and the surface of the cell, the maximum concentration change resulting from adsorption has been calculated and found to be negligible.

V. The values of Λ_c at round concentrations have been tabulated over the concentration range 0.00001 *N* to 0.001 *N* Table VII. The value of Λ_0 was found to be 129.64×0.02 as an average of four determinations.

VI. The Mass-Action "constant" K_E has been found to approach a constant value as the solution becomes sufficiently dilute. The limiting value at zero concentration was found to be 0.020×0.001 . The relative increase of K_E for a tenfold increase in concentration over different regions of the concentration range is shown graphically in Fig. 14.

VII. The empirical equations of Bates and of Kraus, employed to express the relation between equivalent conductance and concentration, have been tested between the concentrations zero and 0.005 *N* and have been found not to be capable of expressing the conductivity data throughout this range.

The author wishes to express his thanks and gratitude to Professor E. W. Washburn under whose direction this investigation has been carried out. At all times his visits to the laboratory have been a source of help and inspiration.

Thanks are also due him together with his associates J. E. Bell, C. J. Baker and Karr Parker who contributed materially in solving the preliminary difficulties of this problem, without which it could not have been carried to a successful conclusion.

URBANA, ILL.

[CONTRIBUTION FROM THE LABORATORY OF PHYSICAL CHEMISTRY OF THE UNIVERSITY OF ILLINOIS. PUBLICATION No. 32.]

THE EQUIVALENT CONDUCTANCE OF ELECTROLYTES IN DILUTE AQUEOUS SOLUTION.

IV. TWO LAWS GOVERNING THE IONIZATION EQUILIBRIUM OF STRONG ELECTROLYTES IN DILUTE SOLUTIONS AND A NEW RULE, BY MEANS OF WHICH THE EQUIVALENT CONDUCTANCE AT INFINITE DILUTION CAN BE DETERMINED FROM A SINGLE CONDUCTANCE MEASUREMENT.

By EDWARD W. WASHBURN.

Received September 25, 1917.

CONTENTS.—1. Statement of the Two Laws. 2. The First Law. 3. The Second Law. 4. A General Rule for Determining Λ_0 Values from a Single Conductance